

Compact-size Picking Area Sensor NA1-PK3 Series

Thank you very much for purchasing Panasonic products. Please read this Instruction Manual carefully and thoroughly for the correct and optimum use of this product. Kindly keep this manual in a convenient place for quick reference.

WARNING

- If this product is used as a sensing device for personnel protection, serious body injury or death could result.
- Never use this product as a sensing device with any press machine, shearing machine, roll grinding machine, forming machine, vulcanizer, or robot etc. for protection of a hand or a part of the body.
- This product does not include a self-checking circuit for safety functions necessary to allow its use as a safety device. Thus, a system failure or malfunction can result in either an energized or a de-energized output condition.
- When this product is used as a sensing device in the following applications and if a problem relating to "law" or "product liability" occurs, Panasonic Electric Works SUNX shall not be liable for the failure and for the damage or less.
 - 1) Use of this product installed to a machinery or a device as a sensing device to detect a hand or a part of the operator's body entering a dangerous area and stop the machinery or the device.
 - 2) Installation of this product to a protection device for preventing to enter a dangerous area and use of this as a sensing device which detects a hand or a part of the operator's body and open / close the door or window.
 - 3) Use of this product as a sensing device for personnel protection (including interlock).
- For sensing devices to be used as safety devices for press machines or for personnel protection, use products which meet standards, such as OSHA, ANSI or IEC etc., for personnel protection applicable in each region or country.
- In case of using as a safety device for press machine, use a product approved by the Ministry of Health, Labor and Welfare in Japan.

1 PART DESCRIPTION

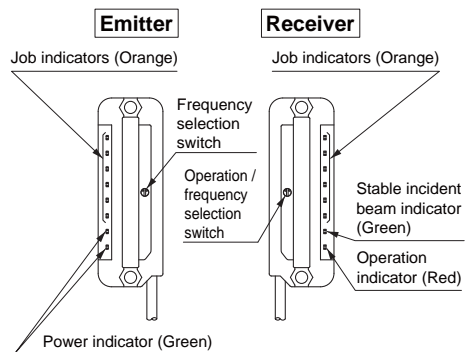

2 MOUNTING

- Use M4 screws with washers and M4 nuts. The tightening torque should be 0.5N·m or less. (Please arrange the screws and the nuts) separately.

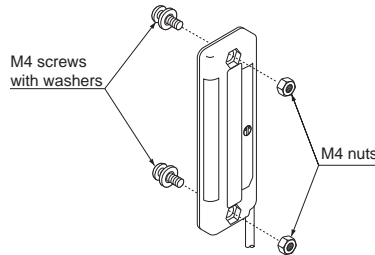

- The sensor protection bracket (MS-NA3-3) (optional) is also available.

Mounting method

1. Insert the sensor protection bracket (MS-NA3-3) from upwards of the sensor body, and match the position of the mounting holes of the sensor body and the sensor protection bracket (MS-NA3-3).
2. Mount with the M4 screws with washers and the M4 nuts enclosed with the sensor protection bracket (MS-NA3-3). The tightening torque should be 0.5N·m or less.

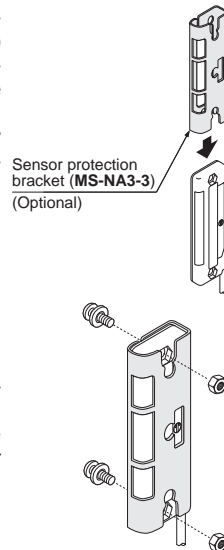

3 I/O CIRCUIT DIAGRAMS

<NPN output type>

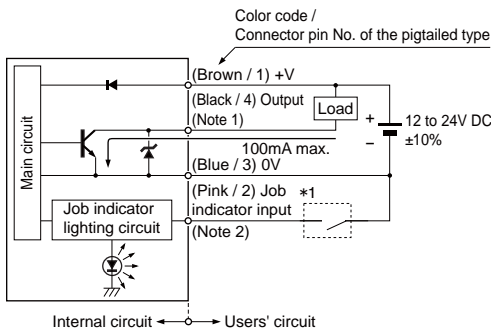

- Notes: 1) The output is not incorporated in the emitter.
2) When the job indicator is used as a large size operation indicator, connect the job indicator input wire (pink) of the emitter and receiver to the output wire (black) of the receiver.

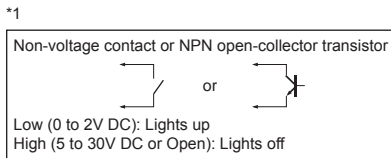

• Connector-pin position (Pigtailed type)

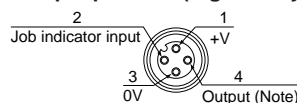

Note: No connection is required for the emitter.

<PNP output type>

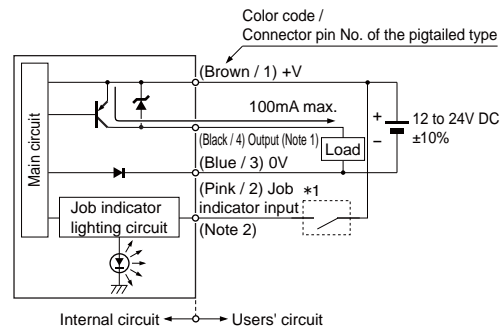

- Notes: 1) The output is not incorporated in the emitter.
2) When the job indicator is used as a large size operation indicator, connect the job indicator input wire (pink) of the emitter and receiver to the output wire (black) of the receiver.

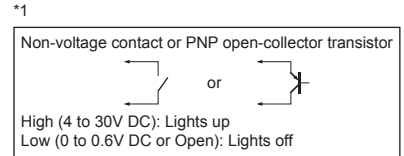

• Connector-pin position (Pigtailed type)

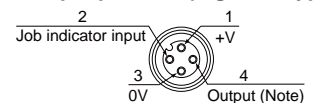

Note: No connection is required for the emitter.

4 BEAM ALIGNMENT

1. Place the emitter and the receiver face to face along a straight line.
2. After the cables have been correctly connected, switch the power ON.
3. Move the emitter in the up, down, left and right directions, in order to determine the range of the beam received condition with the help of the operation indicator (red) on the receiver. Then, set the emitter at the center of this range.
4. Similarly, adjust for up, down, left and right angular movement of the emitter.
5. Further, perform the angular adjustment for the receiver also.
6. Check that the stable incident beam indicator (green) lights up.
7. Interrupt each beam channel with the actual sensing object, and confirm that the sensor operates correctly.

Note: The stable incident beam indicator (green) lights up when all the three beams are stably received by the receiver.

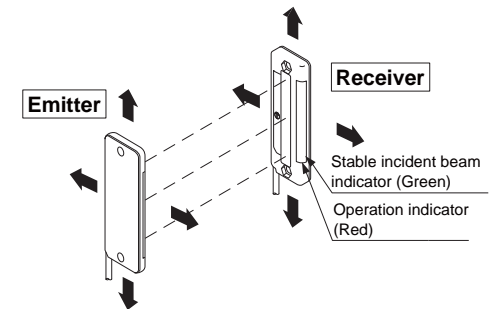

5 SELECTION OF OUTPUT OPERATION

- The output operation can be selected by the operation / frequency selection switch on the receiver. (Make sure to set the switch in the power supply off condition.)

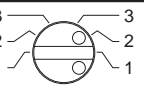
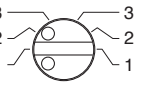
	State of operation / frequency selection switch	Output operation
L-ON		OFF when one or more beams are interrupted.
D-ON		ON when one or more beams are interrupted.

- Notes: 1) Selection of the output operation and the frequency for the receiver is carried out with the same switch. When the output operation is set, be sure to select the same frequency No. of the emitter and the receiver.
- 2) In case the operation / frequency selection switch is set to the position other than 1, 2 or 3, the state of the receiver is in D-ON / frequency 1.

6 INTERFERENCE PREVENTION FUNCTION

- By setting different emission frequencies, three sets of the sensors can be mounted closely as shown in the figure below.

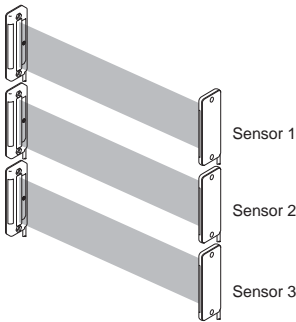



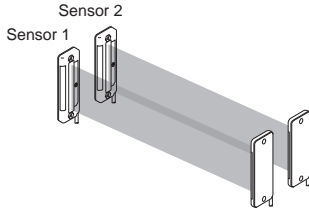

- However, if the sensors are mounted closely as shown in the figure below, up to 2 sets of sensors are possible.

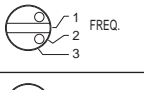
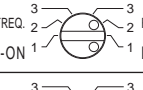

Frequency setting

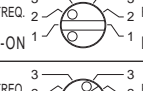
- Set the both emitting and receiving frequency of Sensor 1 to FREQ. 1, the both emitting and receiving frequency of Sensor 2 to FREQ. 2 and the both emitting and receiving frequency of Sensor 3 to FREQ. 3. (Make sure to set the switch in the power supply off condition.)

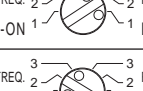
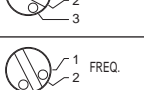
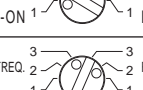
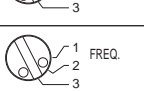
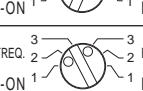
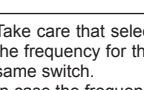
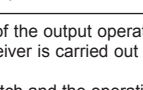
		Emitter		Receiver	
		Frequency selection switch	Operation / Frequency selection switch	Frequency selection switch	Operation / Frequency selection switch
Sensor 1	L-ON				
	D-ON				
Sensor 2	L-ON				
	D-ON				
Sensor 3	L-ON				
	D-ON				

- Notes: 1) Take care that selection of the output operation and the frequency for the receiver is carried out with the same switch.
- 2) In case the frequency switch and the operation / frequency selection switch is set to the position other than 1, 2 or 3, the state of the emitter is in frequency 1 and that of the receiver is in D-ON / frequency 1.

7 SPECIFICATIONS

Item	Type Model No. (Note 1)	NPN output		PNP output	
		2m cable length type	5m cable length type	2m cable length type	5m cable length type
Sensing height		49.2mm			
Sensing range		30 to 300mm			
Beam pitch		24.6mm			
Number of beam channels		3 beam channels			
Sensing object		ø29mm or more opaque object			
Supply voltage		12 to 24V DC±10% Ripple P-P10% or less			
Current consumption		Emitter: 30mA or less, Receiver: 50mA or less			
Output		NPN open-collector transistor		PNP open-collector transistor	
		<ul style="list-style-type: none"> Maximum sink current: 100mA Applied voltage: 30V DC or less (between output and 0V) Residual voltage: 1V or less (at 100mA sink current) 0.4V or less (at 16mA sink current) 		<ul style="list-style-type: none"> Maximum source current: 100mA Applied voltage: 30V DC or less (between output and +V) Residual voltage: 1V or less (at 100mA source current) 0.4V or less (at 16mA source current) 	
Output operation		ON or OFF when one or more beam channels are interrupted, selectable by a switch			
Short-circuit protection		Incorporated			
Response time		10ms or less (when interference prevention is used: 30ms or less)			
Indicators	Emitter	Power indicator: Green LED (lights up when the power is ON) Job indicator: Orange LED (lights up when the job indicator input is Low)		Power indicator: Green LED (lights up when the power is ON) Job indicator: Orange LED (lights up when the job indicator input is High)	
	Receiver	Operation indicator: Red LED (lights up when the output is ON) Stable incident beam indicator: Green LED (lights up when the all beams are stably received) Job indicator: Orange LED (lights up when the job indicator input is Low)		Operation indicator: Red LED (lights up when the output is ON) Stable incident beam indicator: Green LED (lights up when the all beams are stably received) Job indicator: Orange LED (lights up when the job indicator input is High)	
Interference prevention function		Incorporated (Up to 3 units can be closely mounted) (Note 2)			
Ambient temperature		-10 to +55°C (No dew condensation or icing allowed), Storage: -20 to +70°C			
Ambient humidity		35 to 85% RH, Storage: 35 to 85% RH			
Emitting element		Infrared LED (synchronized scanning system)			
Material		Enclosure: Heat-resistant ABS, Lens cover: Acrylic, Display cover: Acrylic			
Cable		0.2mm ² 4-core (emitter: 3-core) oil resistant cabtyre cable, 2m long	0.2mm ² 4-core (emitter: 3-core) oil resistant cabtyre cable, 5m long	0.2mm ² 4-core (emitter: 3-core) oil resistant cabtyre cable, 2m long	0.2mm ² 4-core (emitter: 3-core) oil resistant cabtyre cable, 5m long
		Emitter: Approx. 50g Receiver: Approx. 50g	Emitter: Approx. 105g Receiver: 110g	Emitter: Approx. 50g Receiver: Approx. 50g	Emitter: Approx. 105g Receiver: 110g

- Notes: 1) The model No. with suffix "-J" is pigtailed type. (cable length: 0.3m)

Model No.: **NA1-PK3(-PN)-J**

For the cable connected with the pigtailed type, use the connection cable **CN-24-C2** (cable length: 2m) (optional) or **CN-24-C5** (cable length: 5m) (optional).

- 2) For details, refer to "6 INTERFERENCE PREVENTION FUNCTION."

8 CAUTIONS

- This product has been developed / produced for industrial use only.
- Make sure that the power supply is off while wiring and operation of the selection switch.
- Take care that wrong wiring may damage the sensor.
- Verify that the supply voltage variation is within the rating.
- If power is supplied from a commercial switching regulator, ensure that the frame ground (F.G.) terminal of the power supply is connected to an actual ground.
- Do not use during the initial transient time (0.5 sec.) after the power supply is switched on.
- In case noise generating equipment (switching regulator, inverter motor, etc.) is used in the vicinity of the sensor, connect the frame ground (F.G.) terminal of the equipment to an actual ground.
- Extension up to total 100m is possible with 0.3mm², or more, cable for both emitter and receiver. However, in order to reduce noise, make the wiring as short as possible.
- Do not run the wires together with high-voltage lines or power lines or put them in the same raceway. This can cause malfunction due to induction.
- Take care that the sensor is not directly exposed to fluorescent lamp from a rapid-starter lamp, a high frequency lighting device or sunlight etc., as it may affect the sensing performance.
- Avoid dust, dirt, and steam.
- Take care that the product does not come in contact with water, oil, grease, organic solvents, such as thinner, etc., strong acid or alkaline.
- Make sure to use an isolation transformer for the DC power supply. If an auto-transformer (single winding transformer) is used, this product or the power supply may get damaged.
- In case a surge is generated in the used power supply, connect a surge absorber to the supply and absorb the surge.
- The emitter and the receiver must face each other correctly. If they are set upside down, the sensor does not work.
- In order to turn the switches, a flat-head screwdriver is required. (The blade should be 2.5 × 0.6mm or less)
- This sensor is suitable for indoor use only.

9 INTENDED PRODUCTS FOR CE MARKING

- The models listed under "7 SPECIFICATIONS" come with CE Marking. 
- As for all other models, please contact our office.

Panasonic Electric Works SUNX Co., Ltd.

<http://panasonic-electric-works.net/sunx>

Overseas Sales Division (Head Office)

2431-1 Ushiyama-cho, Kasugai-shi, Aichi, 486-0901, Japan
Phone: +81-568-33-7861 FAX: +81-568-33-8591

Europe Headquarter: Panasonic Electric Works Europe AG

Rudolf-Diesel-Ring 2, D-83607 Holzkirchen, Germany
Phone: +49-8024-648-0

US Headquarter: Panasonic Electric Works Corporation of America

629 Central Avenue New Providence, New Jersey 07974 USA
Phone: +1-908-464-3550

© Panasonic Electric Works SUNX Co., Ltd. 2010
PRINTED IN JAPAN